



FEATURES

- Modern Design with a high-end finish
- Aluminum construction with a semi-textured powder coat or anodized finish
- Micro-Adjustment mechanism ensures precise installation
- Wall plate covers to hide fixings included
- Universal for all key projectors with multiple fixing points
- Distance from wall to projector from 500 mm to 1300 mm
- Internal cable management in tube
- 45° horizontal adjustment

PRODUCT SPECIFICATION

	Dimensions (HxWxD)	Weight	Max capacity	Extension	Colour	Packaging dimensions
WPMV100	590x250x180 mm	4,5 kg	15 kg	500-800 mm	black silver white	750x200x200 mm
WPMV200	890x250x180 mm	5,8 kg	15 kg	800-1300 mm	black silver white	1050x200x200 mm

TECHNICAL





Wall Projector Mount

PRODUCT SPECIFICATION

	Dimensions (HxWxD)	Weight	Max capacity	Extension	Colour	Packaging dimensions
WPMV100	590x250x180 mm	4,5 kg	15 kg	500-800 mm	black silver white	750x200x200 mm
WPMV200	890x250x180 mm	5,8 kg	15 kg	800-1300 mm	black silver white	1050x200x200 mm

TECHNICAL DRAWINGS

WPMV100

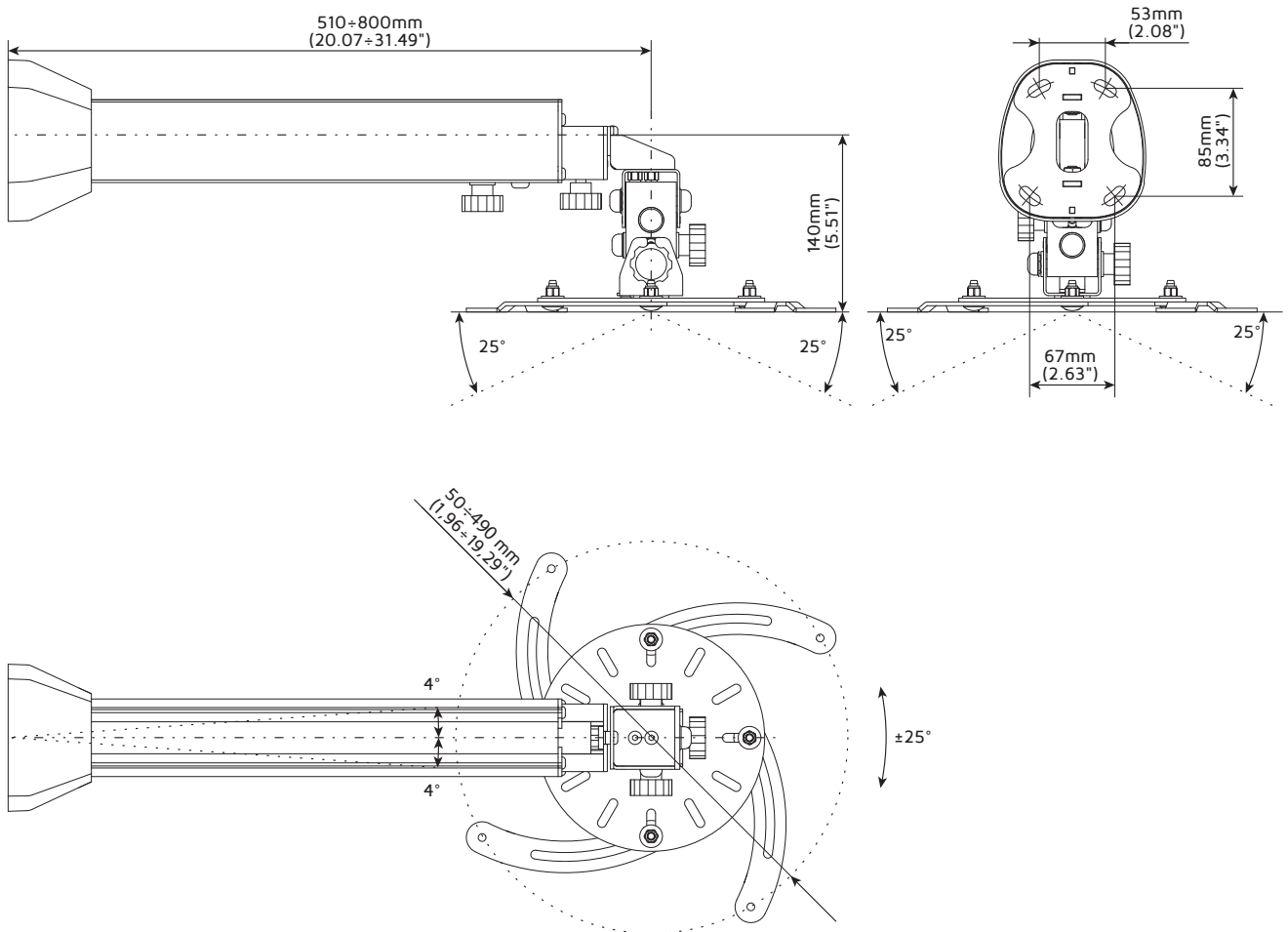

WPMV200

